



LAW-5150-PL Wrap Around Labeler

LABELERS

The LAW-5150-PL Wrap Around Labeler is economical, self contained and easy to operate. This Automatic Wrap Around Labeling system comes equipped with a 6 5/16" wide, 8' long, variable speed conveyor. Armed with the newest and fastest touch screen control technology, it offers an auto teach function and built-in operation manual.

The Stepper Motor Drive delivers accurate and high speed repeatable labeling. Other standard features include a Tilt Label Head, Dual Web Take-up Reels, automatic label head and conveyor belt speed synchronization and many more. Options are available for even more versatility.

The LAW-5150-PL is used in the cosmetic, food and beverage, cleaning and specialty chemical, pharmaceutical, and personal care industries.



SPECIFICATIONS

Standard Construction: Stainless steel & anodized aluminum

Max Web Width: 7" (178mm)

Dispensing Speed: Up to 36M/min

Conveyor Speed: Up to 36M/min

Label Roll Inside Diameter: 3" (76mm)

Label Roll Outside Diameter: 14" (356mm)

Electrical:

- Stepper Motor Drive
- Touch screen controls

Power Requirement:

120VAC, single phase, 50-60Hz

Dimensions:

- Length - 96.12" (2442mm)
- Width - 51.71" (1313mm)
- Height - 53.32" (1354mm)
- Typical Line Height - 36" approx.
- Weight - 441lbs (200kgs)
- Belt Width - 6 5/16" (160mm)

OPTIONS

- Clear Label Sensor
- 8in or 10in Web Width Upgrade
- Conveyor Length Upgrade to 118" (3M)
- Timing Screw Upgrade
- Hot Stamp Coder Integration
- Special electrical requirements
- Custom applications

LAW-5150-PL Wrap Around Labeler



Standard Features:

- Tilt Label Head with Dual Web Take-up Reels
- Touch screen control with auto teach function for new labels
- One touch automatic label detection and setup
- Built-in touch screen operation manual with troubleshooting guide
- Low or Missing Label Detection with automatic stop system to prevent mislabeling
- Stepper Motor Drive for label and power assisted web take up
- Synchronized label head and conveyor speeds
- Non-contact Photo Eye Sensors
- Label Counter
- Count Down Feature with Auto Shut-off (for precise run of set number of labels)

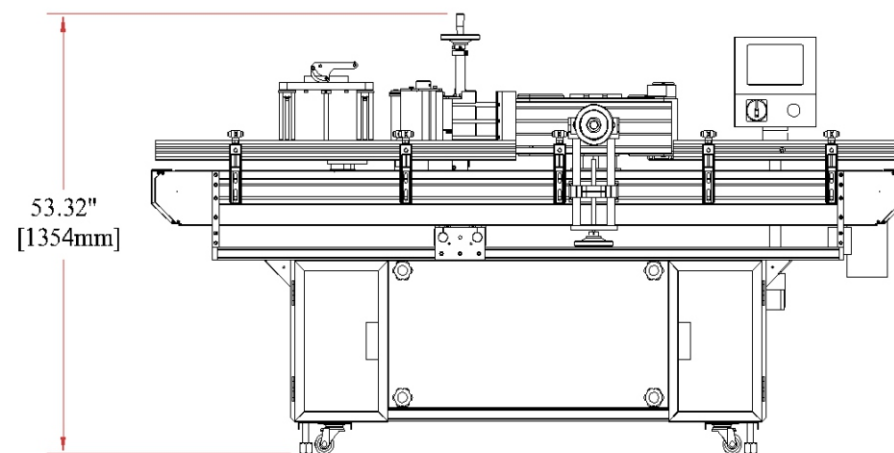
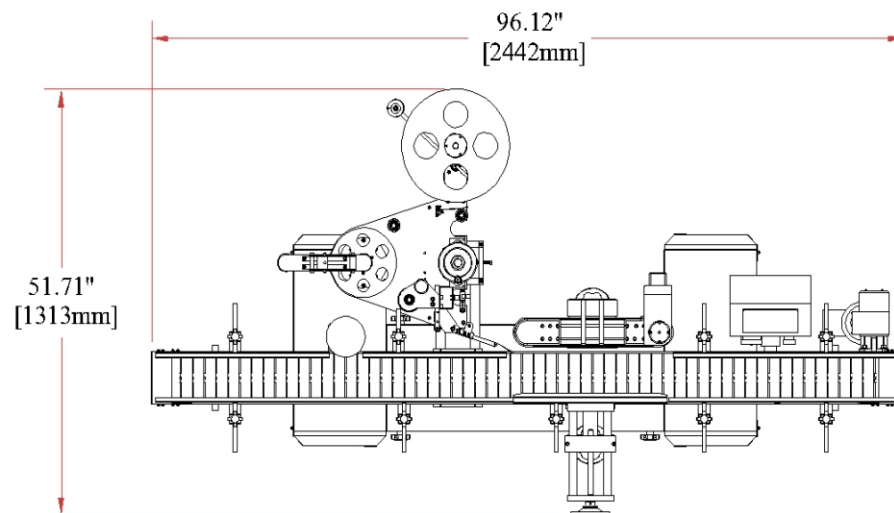

- **Complete line of filling and packaging solutions**
- **Standard filling machines in stock and ready to ship**
- **Economical prices, installation services and excellent customer service**

A PACKAGING SYSTEMS

1500 Lake Street, La Porte, Indiana 46350
Toll Free: 866-369-9030 Fax: 574-975-2711
sales@apackaging.com
www.apackaging.com

