



# LAW-5010-PL Vertical Wrap Around Labeler

# LABELERS

The LAW-5010-PL Vertical Wrap Around Labeler offers a precise and cost-effective solution for pressure sensitive adhesive label application. This automatic labeling system is equipped with a 78.74 inch long, conveyor capable of handling cylindrical container diameters up to 3.5 inch.

Standard features include a Stepper Motor Drive which delivers accurate and high-speed repeatable labeling, automatic label head and conveyor belt speed synchronization, and Low or Missing Label Detection with Auto Shut-off. This Vertical Wrap Around Labeler provides many other standard features easily making any production line more efficient. Options are available for even more versatility.

The LAW-5010-PL is used in the cosmetic, food and beverage, cleaning and specialty chemical, pharmaceutical, and personal care industries.



## SPECIFICATIONS

**Standard Construction:** Stainless steel & anodized aluminum

**Max Web Width:** 6" (152mm)

**Dispensing Speed:** Up to 40M/min

**Conveyor Speed:** Up to 20M/min

**Label Roll Inside Diameter:** 3" (76mm)

**Label Roll Outside Diameter:** 14" (356mm)

### Electrical:

- Stepper Motor Drive
- Touch screen controls

### Power Requirement:

120VAC, single phase, 50-60Hz

### Dimensions:

- Length - 78.74" (2000mm)
- Width - 40.46" (1028mm)
- Height - 40.52" (1029mm)
- Typical Line Height - 36" approx.
- Weight - 353lbs (160kgs)
- Belt Width - 3 29/32" (100mm)

## OPTIONS

- Clear Label Sensor
- 8in or 10in Web Width Upgrade
- Conveyor Width Upgrade for large bottle handling
- Conveyor Length Upgrade to 118" (3M)
- Hot Stamp Coder Integration
- Label Head Tilt Upgrade
- Special electrical requirements
- Custom applications

# LAW-5010-PL Vertical Wrap Around Labeler



## Standard Features:

- Touch screen control with auto teach function for new labels
- One touch automatic label detection and setup
- Built-in touch screen operation manual with troubleshooting guide
- Low or Missing Label Detection with automatic stop system to prevent mislabeling
- Stepper Motor Drive for label and power assisted web take up
- Synchronized label head and conveyor speeds
- Non-contact Photo Eye Sensors
- Label Counter
- Count Down Feature (for precise run of set number of labels)

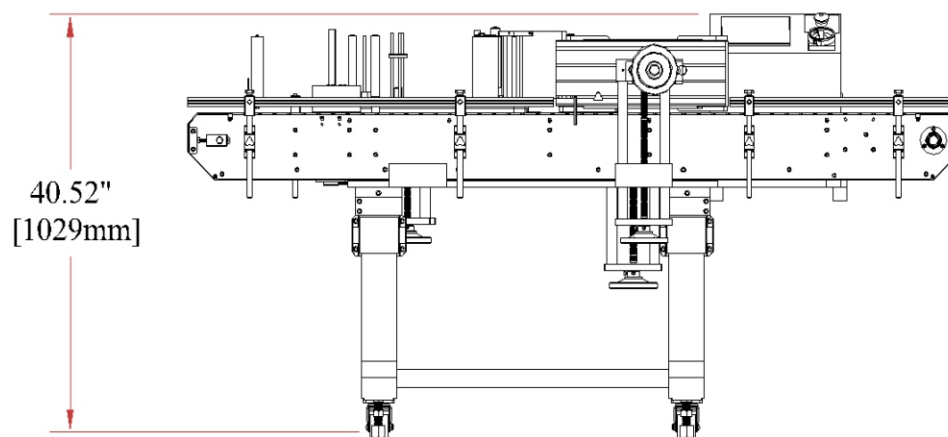
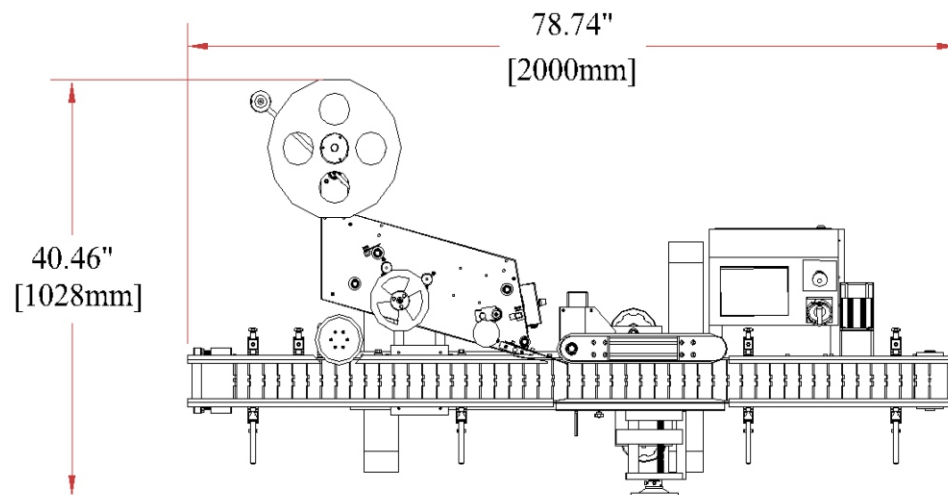

- **Complete line of filling and packaging solutions**
- **Standard filling machines in stock and ready to ship**
- **Economical prices, installation services and excellent customer service**

## A PACKAGING SYSTEMS

1500 Lake Street, La Porte, Indiana 46350  
Toll Free: 866-369-9030 Fax: 574-975-2711  
sales@apackaging.com  
www.apackaging.com

