

AUTOMATIC CHUCK CAPPING MACHINE



APACKS' Automatic Chuck Capper places and torques caps automatically. The cap sorter (sold separately) sorts the caps which are individually picked up by the mechanical swing arm and moved to the chuck head while containers are stabilized by the pneumatic bottle gripping assembly. After the chuck head applies appropriate torque to the cap, the container moves down the APACKS' Conveyor (sold separately).



FEATURES

- Mechanical adjustable Chuck Head
- Cap Delivery Chute, adjustable
- Cap shuttle for one cap size
- Cap Sorting Elevator for flat caps
- Pneumatic Bottle Gripping Assembly for one bottle size
- Polycarbonate Safety Shields with interlock access door
- Container Indexing Logic with bottle sensor and downstream back-up sensor

AUTOMATIC CHUCK CAPPING MACHINE



OPTIONS

- Cap Sorting Elevator
- Cap Sorting Bowl Bulk
- Cap Feeder
- Full-chute Pause
- Dual Heads
- Additional Bottle Gripper Assemblies for different size bottles
- Components for Large Bottles/Caps
- Special electrical requirements
- Custom applications
- Additional remote E-stops

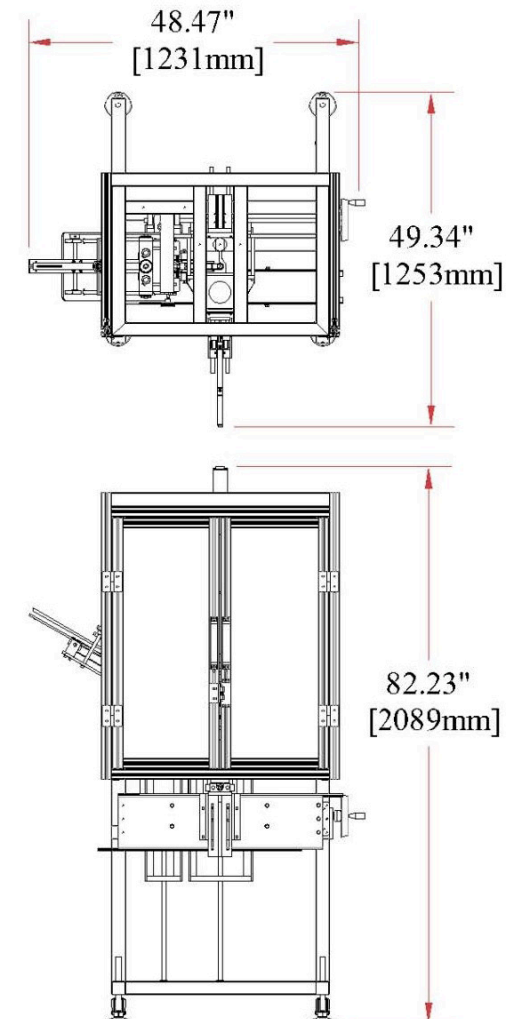

- *Complete line of filling and packaging solutions*
- *Standard filling machines in stock and ready to ship*
- *Economical prices, installation services and excellent customer service*

1500 Lake Street, La Porte, Indiana 46350
Local & Outside US: 219-369-4131
Toll Free: 866-369-9030
Fax: 574-975-2711

sales@apacks.com
www.apacks.com