



Automatic Servo-Driven Pump Fillers

FILLERS

Automatic Servo-Driven Pump Fillers from APACKS can fill up to 12 containers at the same time with virtually any product from thin and foamy to thick and stringy. It is recommended for a wide variety of products including cosmetics, personal care, food and beverages, chemicals, pharmaceuticals and more.

The brain of the APACKS' FSP-4000-AP is the Allen Bradley PLC Controller which allows precise product filling from a fraction of an ounce to several gallons. Built on a heavy-duty 304 stainless steel frame with quality tig-welded construction, this top-of-the-line Filler features anodized aluminum plate or block components to ensure a long life in the harshest environment. The standard 316 stainless steel pumps available with Teflon or Viton elastomers, are easily reversed for string retraction and drip prevention. Modulating speed control for each pump (slow/fast/slow) provides a clean fill, even with foamy products.

The APACKS' FSP-4000-AP increases product yields and production rates with volumetric accuracy, quick and flexible changeovers, and high speed filling at multiple stations. And, now at an even more affordable cost, the Automatic Servo-Driven Pump Filler gives you a quick return on investment.

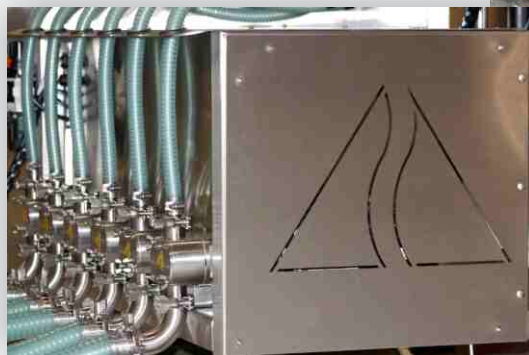
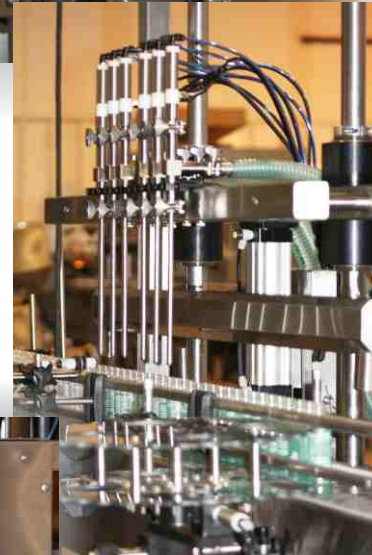

SPECIFICATIONS

Standard Construction: Heavy duty 304SS, tig-welded tube frame

Number of Fill Heads: 1 to 12

Reservoir: 304SS tank is standard

Filling Size: 0.5oz to 5gal

Power Requirement:
220VAC, single phase, 50-60Hz, amperage dependent on number of fill heads

Air Requirement:
3-6CFM @ 90PSI clean, dry, compressed air

Dimensions & Weight: Subject to model configuration

Standard Features:

- Servo-Driven 316SS Gear Pumps with variable speed motors and ramping capability
- 304SS Fill Head Bar
- Allen Bradley® PLC Controls and touch screen HMI with programmable recipes
- Pneumatic Indexing Gates (Entry and Exit)
- Automatic product level sensing float system
- Servo Dive/Height System
- Drip Tray
- Container Neck Locators
- Front panel Start and Emergency Stop
- On/off and speed Controls for Conveyor
- No bottle/No fill Sensor
- Bottle Backup Sensor (downstream)

FILLERS

Automatic Servo-Driven Pump Fillers



OPTIONS

- Automatic Fill Head Spacing
- Special Nozzles (anti-foam, towelette diffuser, bottom-close, etc.)
- Starwheel or Timing Screw Indexing
- Lobe pumps for large particulate filling
- Capacity for Additional Fill Heads
- Product Supply Pump
- Custom applications
- Special electrical requirements
- Lexan Safety Guarding
- Additional remote E-stops
- Sanitary, hazardous, flammable and corrosive environment construction

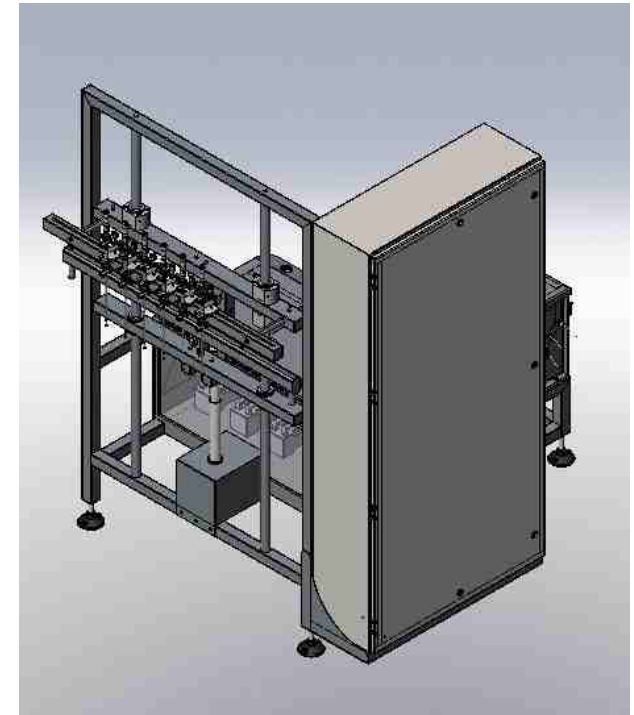
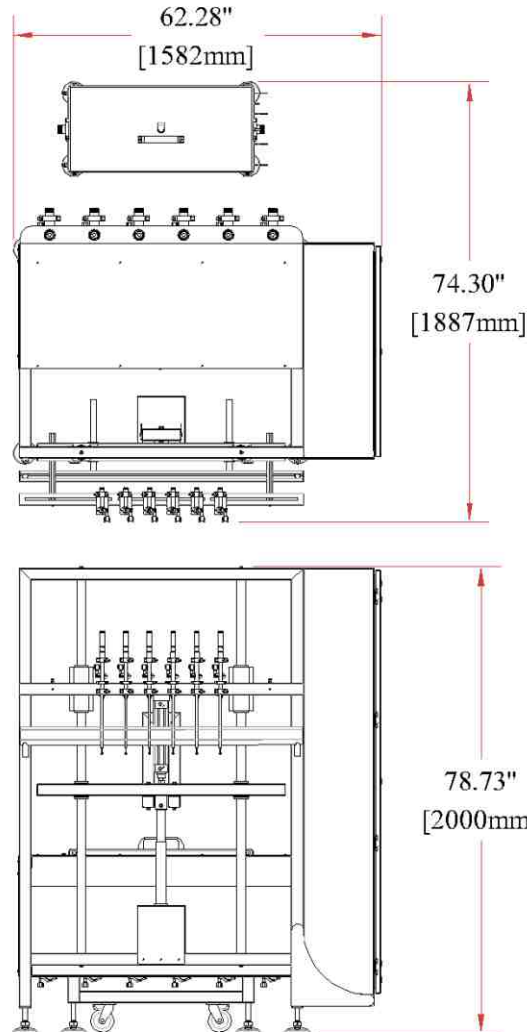

- **Complete line of filling and packaging solutions**
- **Standard filling machines in stock and ready to ship**
- **Economical prices, installation services and excellent customer service**

A PACKAGING SYSTEMS

1500 Lake Street, La Porte, Indiana 46350
Toll Free: 866-369-9030 Fax: 574-975-2711
sales@apackaging.com
www.apackaging.com

