

FILLING MACHINE

AUTOMATIC POSITIVE DISPLACEMENT PUMP FILLERS



APACKS' FRI-4000-AP Automatic Positive Displacement Pump Filler is designed for true adaptability. By offering true positive displacement filling, this filler provides increased filling accuracy with products prone to viscosity change. The pulse-based Gear Pump is able to fill almost all liquids, from low viscosity (thin) to high viscosity (thick) liquids.

The FRI-4000-AP's construction is comprised of a heavy duty 304 stainless steel, tig-welded tube frame and comes standard with 1 to 12 Fill Heads for containers 1" to 12" tall. It also comes standard with PLC Controls and touch screen HMI, product level sensing float system, food grade contact parts, plus many more features. Options are available for even more versatility. Automatic Positive Displacement Pump

Fillers are used in the production of cosmetics, food and beverages, cleaning and specialty chemicals, pharmaceuticals, personal care and more, adding proficiency to any production line.

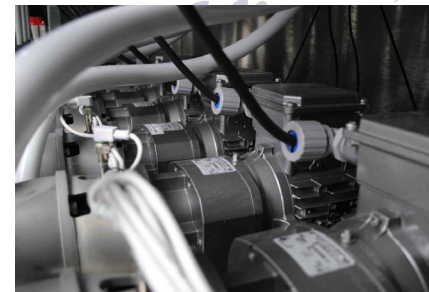

SPECIFICATION

Standard Construction: Heavy duty

304SS, tig-welded tube frame

Number of Fill Heads: 1 to 12

Reservoir: 304SS tank is standard

Filling Size: 0.5oz to 5gal

Power Requirement: 220VAC, single phase, 50-60Hz, amperage dependent on number of fill heads

Air Requirement: 3-6CFM @ 90PSI clean, dry, compressed air

Dimensions & Weight: Subject to model configuration

Standard Features:

- 304SS Fill Head Bar
- PLC Controls with touch screen HMI
- Stainless steel Gear Pumps with variable speed motors and ramping capability
- Pneumatic Indexing Gates (Entry and Exit)
- Automatic product level sensing float system
- Front panel Start and Emergency Stop
- On/off and speed Controls for Conveyor
- No bottle/No fill Sensor
- Bottle Backup Sensor (downstream) delays operation until jam is cleared
- Mounted on 4 heavy duty threaded leveling legs



FILLING MACHINE

AUTOMATIC POSITIVE DISPLACEMENT PUMP FILLERS



OPTIONS

- Diving Heads
- Drip Tray
- Container Neck Locators
- Starwheel or Timing Screw Indexing
- Lobe pumps for large particulate filling
- Capacity for Additional Fill Heads
- Product Supply Pump
- Custom applications
- Special electrical requirements
- Lexan Safety Guarding
- Additional remote E-stops
- Sanitary, hazardous, flammable and corrosive environment construction

APPLICATIONS

- | | | |
|--------------------|-----------------|------------------|
| Vitamin drinks | Oils | Iodine |
| Perfumes | Liquid cleaners | Saline solutions |
| Hair conditioner | Paint | Insect repellent |
| Liquid soap | Degreasers | Water |
| Shampoo | Engine coolant | Juices |
| Creams and lotion | Varnish | Syrups |
| Hand and body wash | Candles | Dressings |
| Hair styling gels | Sealants | Milk |
| Mascara | Grease | Honey |
| Eye liner | Glue | Mayonnaise |
| Makeup remover | Silicone | Cheese |
| Detergents | Cough medicine | Jellies |

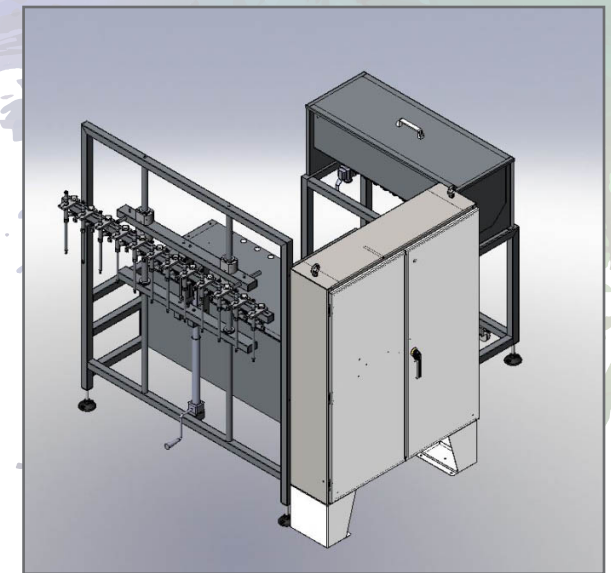
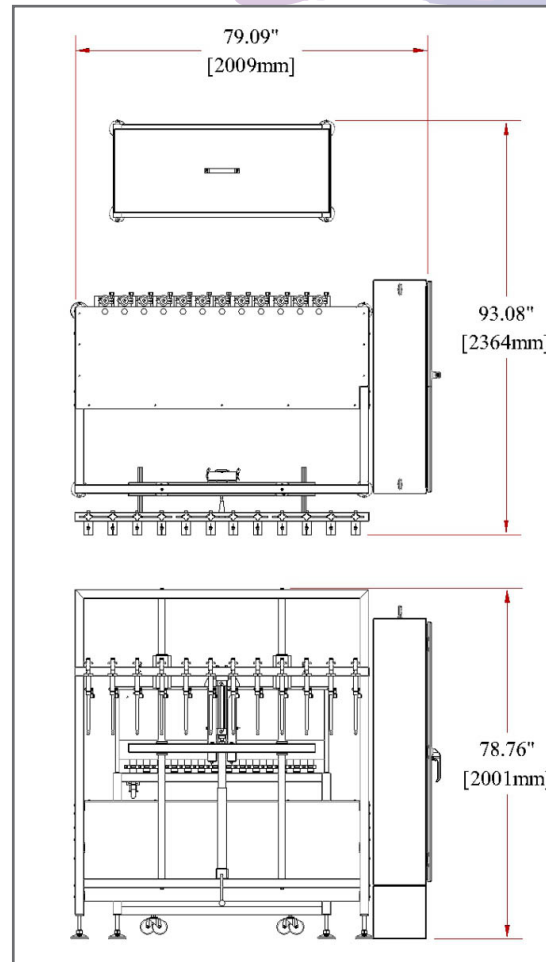

- Complete line of filling and packaging solutions
- Standard filling machines in stock and ready to ship
- Economical prices, installation services and excellent customer service

1500 Lake Street, La Porte, Indiana 46350
Local & Outside US: 219-369-4131
Toll Free: 866-369-9030
Fax: 574-975-2711

sales@apacks.com
www.apacks.com